

Measuring Nanoparticle Exposure

Application Note NSAM-001

The Nanoparticle Surface Area Monitor reports the surface area of inhaled particles deposited in the lung

Nanoparticle Exposure

There is increasing commercial development of nano-scale materials, structures, and devices that take full advantage of the unique properties affecting physical, chemical, and biological behaviors of these nano-scale materials. At this time, the occupational health risks associated with manufacturing and use of nanoparticles are not clearly understood. Workers may be exposed to nanoparticles through inhalation, at levels that greatly exceed ambient concentrations.

Current workplace exposure limits are based on particle mass, but a growing number of experts contend that surface area, rather than mass, should be used for nanoparticle exposure and dosing. Nanoparticles have far more surface area for the equivalent mass of larger particles, which increases the chance they may react with the body (Shanbhag et al., 1994; Oberdörster, 1996; Donaldson et al., 1998). As a result, assessing workplace conditions and personal exposure based on the measurement of particle surface area is of increasing interest.

It is well known that lung deposition is the most efficient way for airborne particles to enter the body and potentially cause adverse health effects. Properties that contribute to the toxic effects of nanoparticles include: solubility, particle morphology, particle size, composition, surface chemistry, surface coatings, and surface area. Experts assert that if nanoparticles (1) can deposit in the lung and remain there, (2) have an active surface chemistry, and (3) interact with the body then, there is the potential for exposure and dosing. Recent research (Oberdörster, 2001) has shown that **surface area** plays an important role in the toxicity of nanoparticles and is the measurement metric that best correlates with particle-induced adverse health effects. The potential for adverse health effects is directly proportional to particle surface area (Driscoll 1996; Oberdörster 2001).

Lung Deposition

Inhalation is the most common route for exposure to airborne particles. In industrial hygiene workplace monitoring, it is common to sample aerosols according to their deposition in a specific region of the human lung. Inhalable, thoracic and respirable size fractions are common examples of size-selective sampling that is done for occupational exposure monitoring. It is important to understand the mechanisms of lung deposition for nanoparticles, particularly in the range from 1 to 1000 nanometers.

The human respiratory tract consists of three major regions. The uppermost region is the extrathoracic region. The middle portion is the tracheobronchial region, and the innermost portion is the alveolar



region. The uptake of inhaled particles by our body is determined by where they deposit in the respiratory tract. The figure below shows the various regions of the human lung and is the model used by the International Commission of Radiological Protection (ICRP) and the U.S. Environmental Protection Agency (US EPA) to define and characterize human lung deposition.

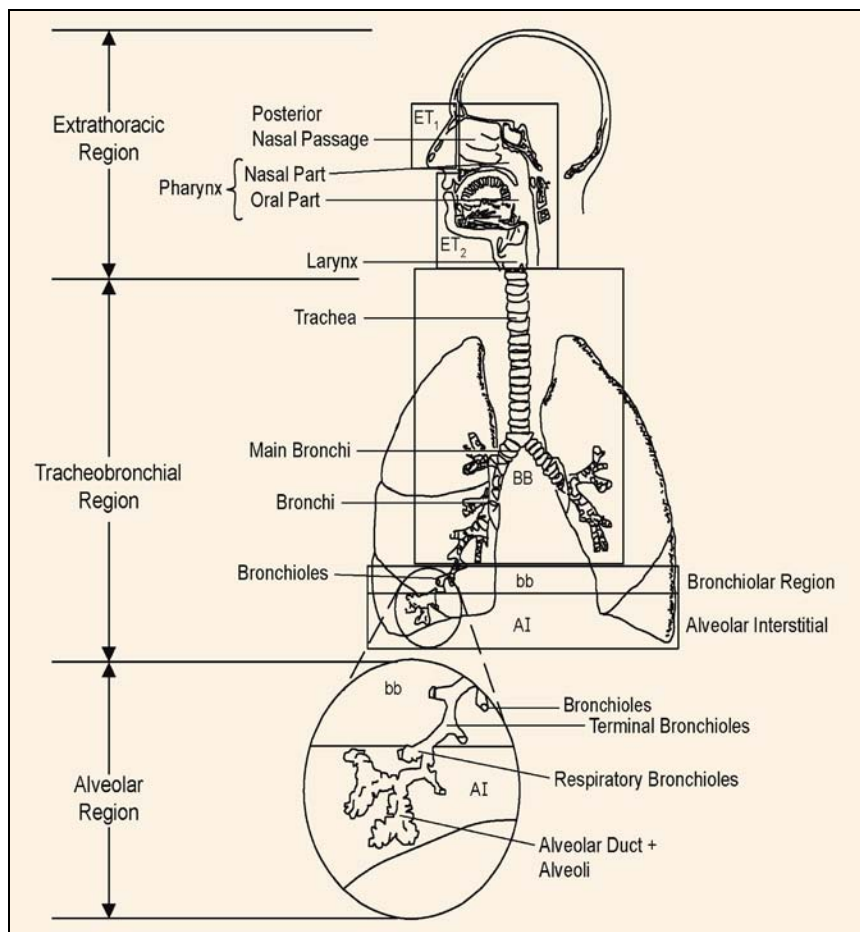

Based on International Commission of Radiological Protection (1994) and U.S. Environmental Protection Agency (1996a). Air Quality Criteria for Particulate matter, 2004, p 6-5.

In 1966, the ICRP developed a comprehensive lung deposition model for radioactive aerosols. Several parameters are required to construct the model including the breathing rate, lung volume, activity, nose/mouth breathing, and others. The deposition curves (for tracheobronchial and alveolar deposition) derived from the model vary based on these parameters. For industrial hygiene applications, Robert Phalen (Particle Size-Selective Sampling for Particulate Air Contaminants, (1999), Ed. James H. Vincent, American Conference for Governmental Industrial Hygienists (ACGIH), Cincinnati, OH) developed a definition for a reference worker that is used to derive the deposition curves. The reference worker is defined as follows:

Physiological Parameters

Subject =	Adult male
Functional Residual Capacity =	2200 cc
Extra-Thoracic Dead Space =	50 cc
Bronchial Dead Space =	49 cc
Bronchiolar Dead Space =	47 cc
Height =	175 cm
Tracheal Diameter =	1.65 cm
First Bronchial Diameter =	0.165 cm

Other parameters considered in the model include the following:

Activity Related Parameters

Activity level =	Light exercise
Activity Type =	Nose breathing only
Ventilation Rate =	1.3 m ³ /hr
Respiratory Frequency =	15.0 breaths/minute
Tidal Volume =	1450 cc
Volumetric Flow Rate =	725 cc/sec
Fraction Breathed through Nose =	1.0

Aerosol Parameters

Activity Mean Aerodynamic Diameter =	0.001 μm – 0.5 μm
Geometric Standard Deviation =	1.0
Density =	1.0 g/cc
Shape Factor =	1.0

The following curves for tracheobronchial and alveolar lung deposition are based on the reference worker parameters and the ICRP model.

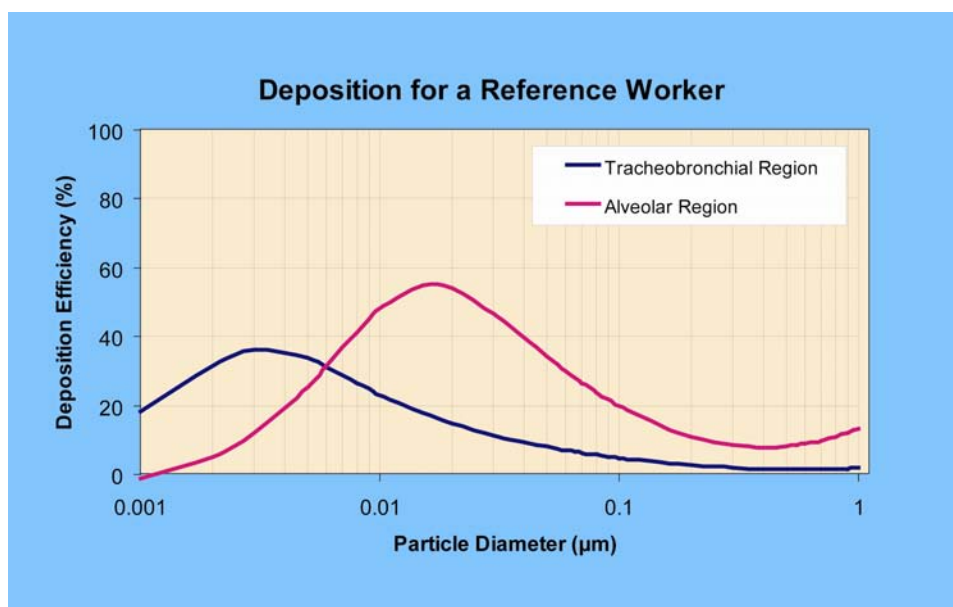

The tracheobronchial deposition curve represents the fraction of aerosol that deposits in the tracheobronchial region of the lung and the alveolar deposition curve represents the fraction of the aerosol that deposits in the alveolar region of the lung.

As discussed, for exposure assessment applications it is common to sample aerosols relevant to their deposition in a specific region of the human lung. This is often referred to as size-selective health hazard sampling. The criterion for size-selective sampling depends on the aerosol being sampled. For example, for coal dust, the health effects relate to the deposition deep in the alveolar regions of the lung, so the respirable fraction of the aerosol is the metric of interest. In contrast, the thoracic fraction of the aerosol is of interest for sampling cotton dust.

The Instrument, the Measurement, and Calibration

The patented Model 3550 Nanoparticle Surface Area Monitor* indicates the human lung-deposited surface area of particles in units of square micrometers per cubic centimeter ($\mu\text{m}^2/\text{cc}$), corresponding to tracheobronchial (TB) and alveolar (A) regions of the lung.

The Instrument

The Model 3550 is based on diffusion charging of sampled particles, followed by detection of the charged aerosol using an electrometer. Using an integral pump, an aerosol sample is drawn into the instrument through a cyclone with a 1 micrometer (μm) cut point. The sample flow is split, with one stream going through a set of carbon and HEPA filters and an ionizer to introduce positively charged ions into the a mixing chamber. The other aerosol flow stream is mixed with the ionized stream in a mixing chamber and charged aerosol and excess ions move onto an ion trap. The instrument can be switched between sampling for the tracheobronchial (TB) and alveolar (A) fractions of the total aerosol. This is achieved by changing the ion trap voltage to either the tracheobronchial (TB) or alveolar (A) response settings. The ion trap essentially acts as an inlet conditioner or a size-selective sampler for the electrometer, by collecting the excess ions and particles that are not of a charge state (i.e., surface area/size) corresponding to the tracheobronchial or alveolar response settings. The aerosol then moves on to the electrometer for charge measurement. In the electrometer, current is passed from the particles to a conductive filter and measured by a very sensitive amplifier. The charge measured by the electrometer is directly proportional to the surface area of the particles passing through the electrometer. A microprocessor controls the instrument flows and measures various operational parameters and converts the measurement output into units of square micrometers per cubic centimeter ($\mu\text{m}^2/\text{cm}^3$). While the Model 3550's performance is well characterized up to 400 nanometers, the instrument's response for larger particles is not as clearly understood.

The Measurement

The Model 3550, when set to either tracheobronchial (TB) or alveolar (A) response settings, matches the corresponding lung deposition criteria of particles for a reference worker as predicted by human lung deposition models published by the International Commission on Radiological Protection (ICRP, 1995). The lung deposition is calculated for a reference worker as defined in a publication by the American Conference of Governmental Industrial Hygienists (ACGIH, *ed.* Vincent J.H., 1999).

The Model 3550 does not measure the total active surface area (i.e., Fuch's surface area) of particles suspended in air. It indicates the surface area of the fraction of these particles that deposit in either the tracheobronchial or alveolar regions of the human respiratory tract. The ion trap voltages are optimized to correspond to the ICRP model-based tracheobronchial and alveolar lung deposition curves, and the Model 3550 indicates the lung deposited surface area, not the total active surface area of the aerosol sampled. The current measured by the electrometer downstream of the ion trap in the Model 3550, when set to either tracheobronchial or alveolar response settings, correlates well with the calculated value of deposited surface area of particles in these respective regions of the lung as shown in the following figure.

*U.S. Patents 6,544,484 and 7,812,306

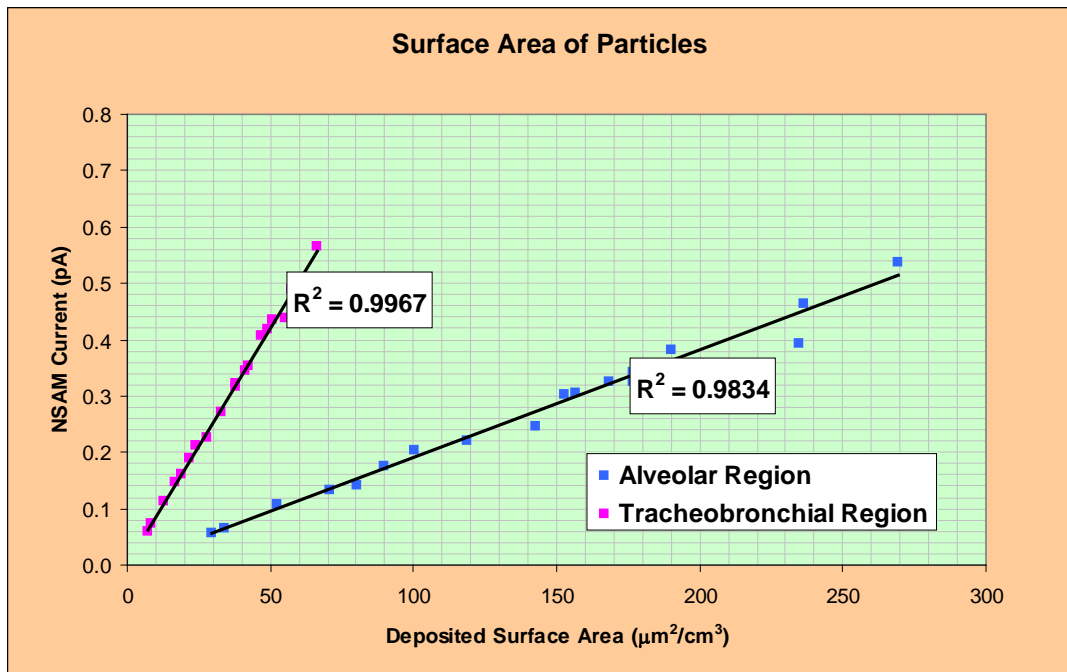

Calibration

The Model 3550 is calibrated using a sodium chloride (NaCl) solution. Typically, atomizing a low concentration 0.01% sodium chloride solution is adequate to generate an aerosol with size distribution centered at 60 nm. The classifier assembly, consisting of a TSI Model 3080 + TSI Model 3081 Long DMA is then used to classify the poly-dispersed sodium chloride aerosol to generate monodispersed 80 nm particles that are used to calibrate the Model 3550. The calibration setup is shown in the figure below.

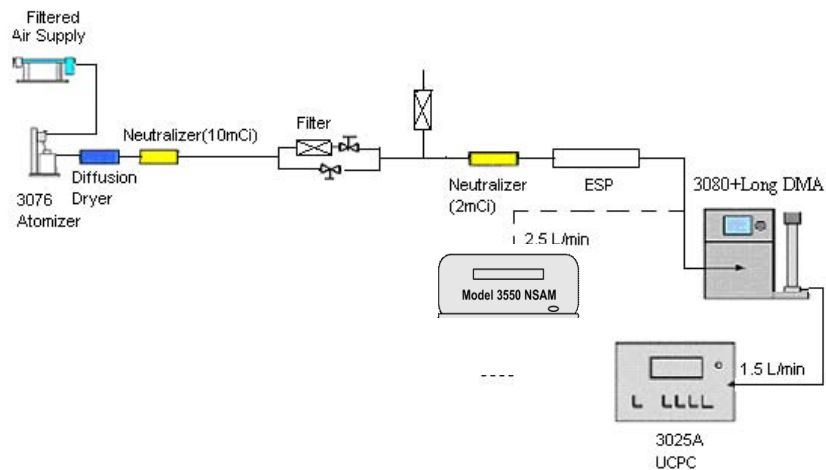

The Model 3550 calibration constant is determined by running the monodispersed aerosol simultaneously between the SMPS and the Model 3550. The total surface area of the 80 nm particles determined by the SMPS is then multiplied by the lung deposition efficiency of 80 nm particles as determined by the ICRP lung deposition curve for a reference worker. This is the lung deposited surface area for 80 nm particles as determined by the SMPS. A ratio of the Model 3550's response to SMPS determined lung deposited surface area is the calibration factor. This method is used for both the tracheobronchial (TB) and the alveolar (A) deposition by changing the Model 3550's response and using the appropriate ICRP lung deposition efficiency curve. The resulting calibration factors for tracheobronchial (TB) and alveolar (A) are programmed into the Model 3550.

The verification of the Model 3550 for tracheobronchial (TB) and alveolar (A) response settings are performed using polydispersed sodium chloride solution. Instead of classifying the sodium chloride aerosol, the entire size distribution is used for comparing the Model 3550's response with the SMPS. The SMPS obtained surface area distribution is multiplied by the ICRP curves (for TB and A) obtained for the entire size range of interest, which gives the total lung deposited surface area. This number is then compared with the Model 3550 reading averaged over the entire period of SMPS sampling. They must be within $\pm 10\%$ (for TB and A) for the Model 3550 to pass calibration and verification testing.

Applications

The Model 3550 provides a simple and fast solution for indicating the surface area equivalent dose of particles in the size range of 10 to 1000 nanometers. The Model 3550 is well suited for the following applications:

- Monitoring workplace exposure to nanoparticles
 - Industrial hygiene surveys
 - Ambient work area monitoring
 - Baseline screening and trending
 - Engineering studies
- Material science and production process monitoring
- Inhalation toxicology research studies
- Epidemiology research studies

Theory of Operation

The Model 3550 is based on diffusion charging of sampled particles, followed by detection of the charged aerosol using an electrometer. An aerosol sample is drawn into the instrument continuously at a rate of 2.5 L/min. The flow is split with 1 L/min passing through two filters (a carbon and a HEPA) and an ionizer and 1.5 L/min of aerosol sample flow.

The flow streams are merged in a mixing chamber where particles in the aerosol flow mix with the ions carried by the filtered clean air. This patented *counter-flow diffusion charging*** brings the aerosol particles into a defined, charged state. The separation of particles from direct interaction with the corona needle and/or the strong field near it reduces particle loss and makes the charging process more efficient and reproducible. The charged aerosol then passes through an ion trap to remove excess ions and charged aerosol. The aerosol then moves on to an electrometer for charge measurement. In the electrometer, current is passed from the particles to a conductive filter and measured by a very sensitive amplifier. A microprocessor controls the instrument flows and measures various operational parameters and converts the measurement output into units of square micrometers per cubic centimeter ($\mu\text{m}^2/\text{cc}^3$).

**U.S. Patent No. 6,544,484

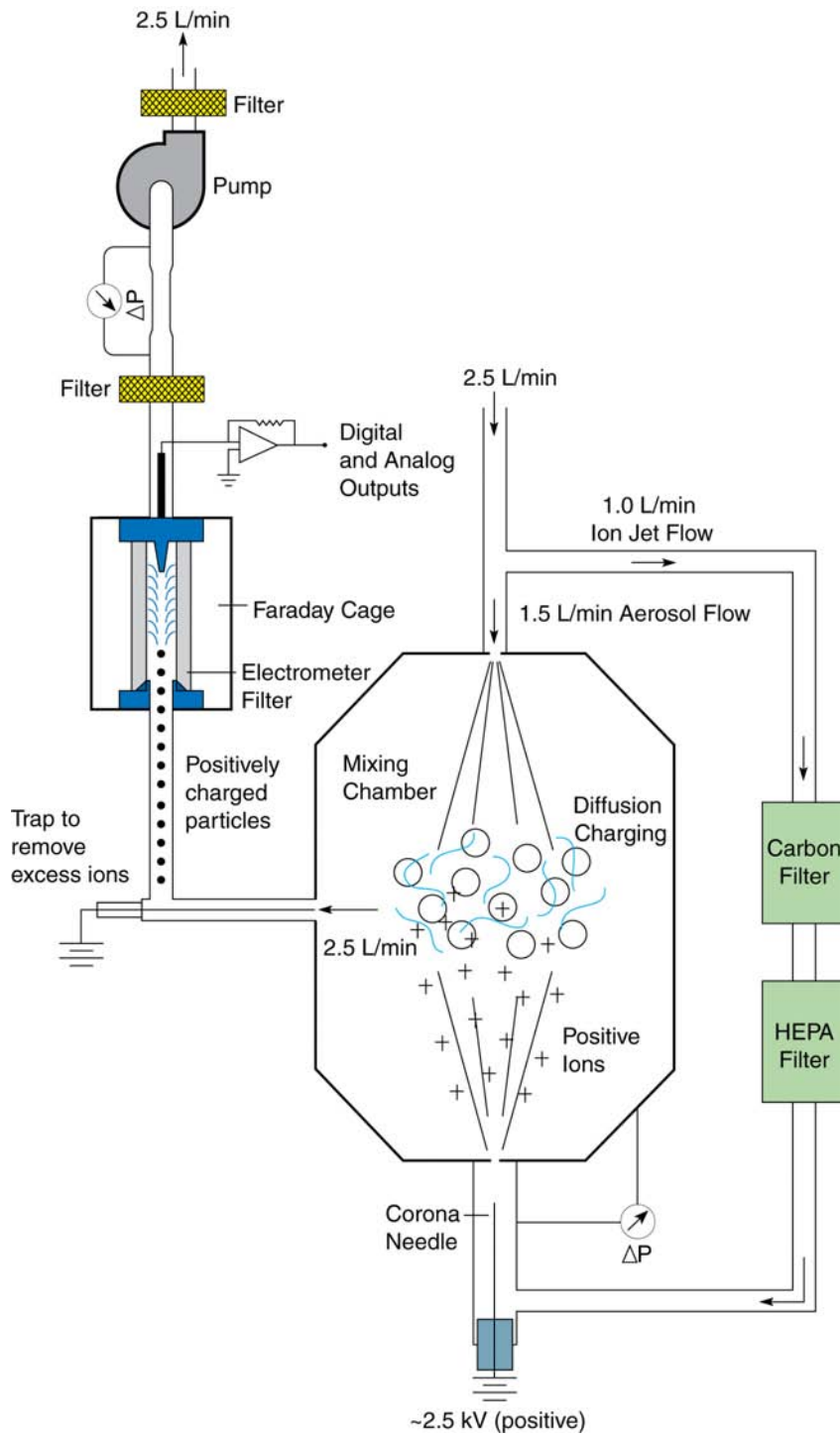

TSI Incorporated – 500 Cardigan Road, Shoreview, MN 55126 U.S.A

USA	Tel: +1 800 874 2811	E-mail: particle@tsi.com	Website: www.tsi.com
UK	Tel: +44 149 4 459200	E-mail: tsiuk@tsi.com	Website: www.tsiinc.co.uk
France	Tel: +33 491 11 87 64	E-mail: tsifrance@tsi.com	Website: www.tsiinc.fr
Germany	Tel: +49 241 523030	E-mail: tsigmbh@tsi.com	Website: www.tsiinc.de
India	Tel: +91 80 41132470	E-mail: tsi-india@tsi.com	
China	Tel: +86 10 8251 6588	E-mail: sibeijing@tsi.com	
Singapore	Tel: +65 6595 6388	E-mail: tsi-singapore@tsi.com	



TRUST. SCIENCE. INNOVATION.

Contact your local TSI Distributor or visit our website www.tsi.com for more detailed specifications.