

Calibration Process of the Volatile Particle Remover for Engine Exhaust Measurements

Application Note EM-003

The United Nations Economic Commission for Europe (UNECE) is tasked with creating a uniform set of regulations for vehicle design to facilitate international trade. UN-ECE Regulation 83 covers emission of pollutants according to engine fuel requirements and requires particle number measurements in light-duty vehicle exhaust. One of the details the regulation calls out is the conditioning of the vehicle exhaust gas by a volatile particle removal system (VPR). The VPR characteristics and calibration requirements are specified in the regulation. TSI's fully compliant VPR solution is the Rotating Disk Thermodilutor and Thermal Conditioner, Model 379020A-30. In combination with the particle number counter (PNC), TSI Model 3790¹, the entire system is a small and easy to operate solution for certification and R&D measurements in the automobile industry and related industries.

Volatile Particle Removal System (VPR) Calibration

The VPR system consists of three components:

- PND1 - Particle Number Dilutor 1: Model 379020A Rotating Disk Thermodilutor
 - ET - Evaporation Tube
 - PND2 - Particle Number Dilutor 2
- } Model 379030 Thermal Conditioner

These three parts are the subject of calibration. In general the calibration setup makes use of aerosol generators to produce the challenge aerosol and condensation particle counters to determine penetration or removal efficiencies.

Three calibration options are available.

Part Number	Description
CL-379020A	Standard Calibration for Rotating Disk Thermodilutor
CL-379030	Standard Calibration for Thermal Conditioner
PMP-379020A	PMP ² calibration for 379020A-30

¹The Model 3790 Engine Exhaust Condensation Particle Counter (EECPC) was developed for and used during the testing phase of the PMP² and is fully compliant with all UN-ECE Regulation 83 particle number counter requirements

²PMP - GRPE Particle Measurement Program. Inter-laboratory correlation exercise undertaken to provide measurement recommendations for light duty and heavy duty vehicle emissions.



Standard Calibration of the Rotating Disk Thermodiluter 379020A (PND1)

During standard calibration of the Rotating Disk Thermodiluter (Model 379020A), dry and monodisperse sodium chloride aerosol is generated by an aerosol generator (TSI model 3076) and a size classifier (TSI model 3080L) is used to narrow the aerosol size distribution. The particle number concentration is measured upstream and downstream of the thermodiluter using two condensation particle counters (CPC). One at the undiluted input (raw gas) and one at the diluted output of the 379020A. The dilution ratio (DR) is calculated for a number of different settings.

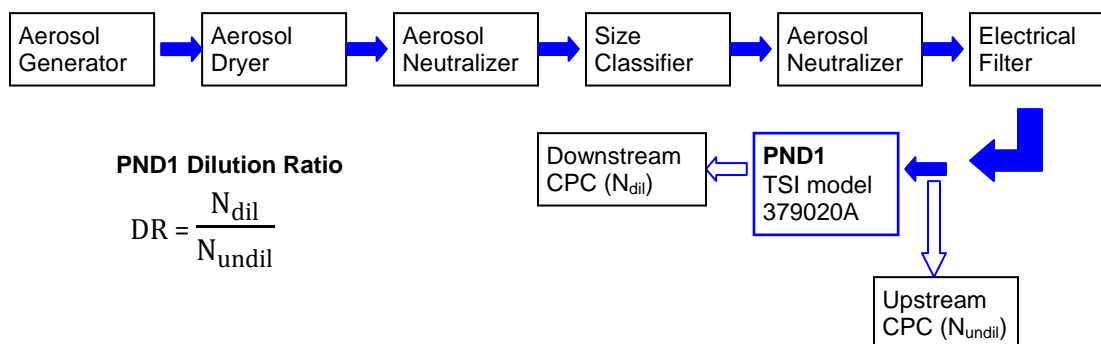

Thermodiluter Calibration Steps

1. Zero and leak tests. A comparison test of the two CPCs is performed at the upstream sampling point before calibration. A leakage test for the PND1 is also part of the procedure. During the leak test a potentiometer controlling the rotation speed of the disk is set to zero, and the downstream CPC should detect <0.5 particles/cm³.
2. Dilution ratio calibration. The head temperature of the 379020A is set to 80°C, and the rotating speed is adjusted using the potentiometer. Calibration is performed at 8 dilution ratios and speed/potentiometer settings are recorded. Setpoints and dilution ratios are documented on the calibration certificate.

Standard Calibration of the Thermal Conditioner 379030 (ET-PND2)

During standard calibration of the Thermal Conditioner (Model 379030), polydisperse soot aerosol is generated and fed through the unit. The particle number concentration is measured upstream and downstream of the thermal conditioner using two condensation particle counters (CPC). One at the undiluted input and one at the diluted output of the 379030. Diffusion losses as well as dilution factor dependent thermophoretic losses are determined, by using two different evaporation tube (ET) temperature settings.

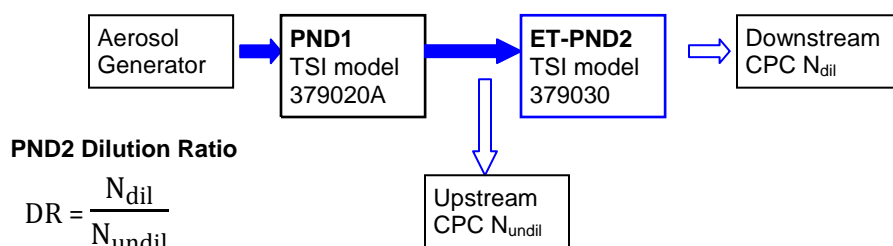

Thermal Conditioner Calibration Steps

1. A comparison test of the two CPCs is performed at the downstream sampling point before calibration. A leakage test for the 379030 is also part of the procedure. During the leak test 1) the potentiometer controlling the rotation speed of the disk at PND1 is set to zero, 2) the pumps for raw gas transport,

primary and secondary dilution air are switched on and 3) PND1 and ET heating are turned off. The downstream CPC should then record <0.5 particles/cm³ for secondary dilution set to 1 as well as 11.

2. The first dilution ratio calibration of the 379030 is carried out with heating of the ET switched off. The secondary dilution is varied in 7 steps and upstream and downstream concentrations are compared to determine the nominal dilution ratio (DR). The calculated DR is compared to the nominal DR and plotted on the calibration certificate. Diffusion losses are calculated and should be $<6\%$.
3. The second dilution ratio calibration of the 379030 is carried out with the ET at 300 °C (standard operating condition). The secondary dilution is varied in 7 steps and upstream and downstream concentrations are compared to determine the nominal dilution ratio (DR). The calculated DR is compared to the nominal DR and plotted on the calibration certificate. Diffusion losses are considered and calculated, and then thermophoretic losses can then be determined.

PMP Compliant Calibration of Rotating disk Thermodilutor and Thermoconditioner 379020A-30

This primary, extensive calibration should be performed for new units and following any major maintenance. It includes calibration of the particle concentration reduction factors (PCRF or f_r) and the volatile particle removal efficiency across the full range of dilution settings.

It is recommended that a periodic validation check of the PCRF calibration be performed every 6 to 12 months. It may be limited a single setting check—typically at the setting most often used for measurements.

The PMP compliant calibration applies to the combined system of 379020A and 379030.

PMP Calibration Steps

1. Particle concentration reduction factors (PCRF).
 - a. The PCRF is determined using solid soot particles with an electrical mobility diameter of 30, 50 and 100 nm across a matrix of at least 15 nominal dilution settings. At least 5 PND1 dilution factors spaced logarithmically across the dilution factor range for VPRs should be used and at least 3 dilution settings should be used for PND2.

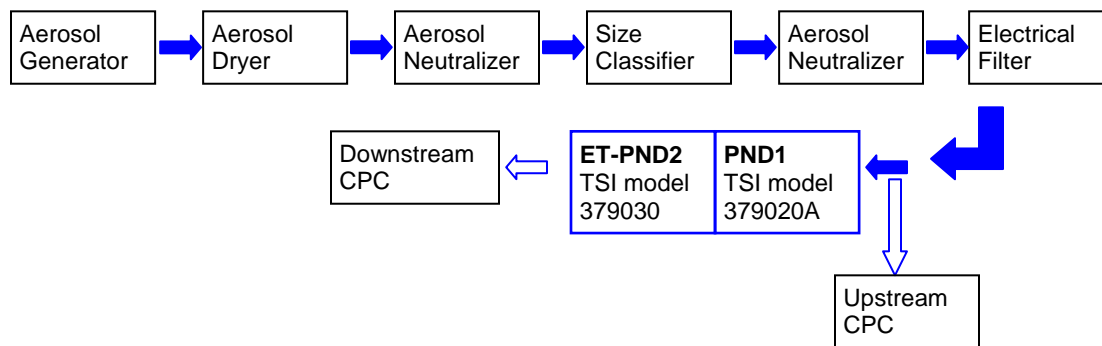

- b. For each particle diameter and dilution setting the PCRF is calculated. For each dilution setting the mean PCRF is calculated from the three size-dependent PCRFs and the mean PCRF is plotted in the calibration certificate.
- c. The requirements are:
 - i. PCRF(30nm) is 0.95 to 1.3 times of PCRF(100nm)
 - ii. PCRF(50nm) is 0.95 to 1.2 times of PCRF (100nm)

2. Volatile Particle Removal (VPR) Efficiency

- a. VPR Efficiency is measured using monodisperse, tetracontane (C₄₀) particles at ET temperature of 300°C, lowest PND1 dilution factor and PND2 setting of 10.
- b. The requirement is to achieve at least 99.0% removal of 30 nm tetracontane particles with an inlet concentration of greater than or equal to 10,000 cm⁻³.

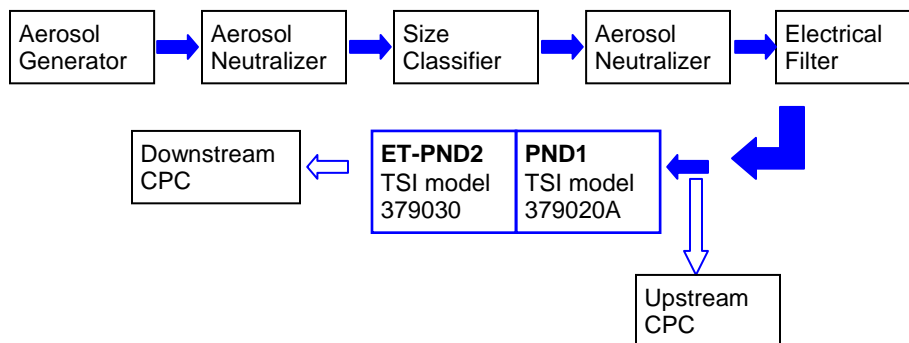

Summary

Standard calibration utilizes monodisperse salt calibration aerosol for Model 379020A Rotating Disk Thermodiluter (RDD) PND1 and polydisperse soot calibration aerosol for Model 379030 Thermal Conditioner (ET-PND2).

PMP calibration utilizes monodisperse salt to determine particle concentration reduction factor (PCRFs) and monodisperse tetracontane for the volatile removal efficiency determination.

Discussions are on-going to evaluate if sodium chloride or soot aerosol should be used for calibration, but currently sodium chloride is part of the actual valid regulation.

TSI Incorporated – 500 Cardigan Road, Shoreview, MN 55126 U.S.A

USA	Tel: +1 800 874 2811	E-mail: particle@tsi.com	Website: www.tsi.com
UK	Tel: +44 149 4 459200	E-mail: tsiuk@tsi.com	Website: www.tsiinc.co.uk
France	Tel: +33 491 11 87 64	E-mail: tsifrance@tsi.com	Website: www.tsiinc.fr
Germany	Tel: +49 241 523030	E-mail: tsigmbh@tsi.com	Website: www.tsiinc.de
India	Tel: +91 80 41132470	E-mail: tsi-india@tsi.com	
China	Tel: +86 10 8251 6588	E-mail: tsibeijing@tsi.com	
Singapore	Tel: +65 6595 6388	E-mail: tsi-singapore@tsi.com	

Contact your local TSI Distributor or visit our website www.tsi.com for more detailed specifications.



TRUST. SCIENCE. INNOVATION.